

FEATURES

- **WIDE BAND APPLICATION:** 0.5 to 3.0 GHz
- **LOW CURRENT CONSUMPTION:** 14 mA at 5 V TYP.
- **MULTIPLE DIVIDE RATIOS:** 64/128/256
- **HIGH INPUT SENSITIVITY:**
-14 to +10 dBm @ 1.0 GHz to 2.7 GHz
- **OUTPUT VOLTAGE:** 1.6 Vp-p (CL = 8 pF load)
- **SMALL SOP 8 PIN PACKAGE**
- **TAPE AND REEL PACKAGING AVAILABLE**

DESCRIPTION

The UPB1505GR is a Silicon MMIC Prescaler manufactured using the NESAT III process. The NESAT III process produces transistors with f_T approaching 20 GHz. The device's 3 GHz operating range makes it suitable for wide-dynamic range DBS satellite receivers, compressed video or spread-spectrum receivers.

NEC's stringent quality assurance and test procedures ensure the highest reliability and performance.

TEST CIRCUIT

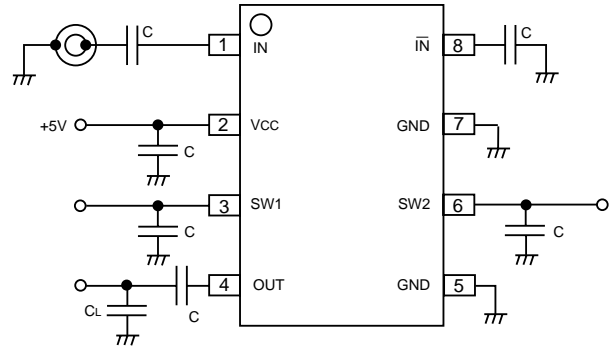

		SW2	
		5 V	Open
SW1	+5 V	1/64	/
	Open	1/128	

Notes:

1. All Capacitors are 1000 pF except load capacitor (CL) at the output should be 8 pF.
2. To minimize self-oscillation, circuit board traces to the input and output pins should be isolated from each other as much as possible.

ELECTRICAL CHARACTERISTICS (TA = -40 to +85°C, VCC = 4.5 to 5.5 V)

PART NUMBER PACKAGE OUTLINE			UPB1505GR G08		
SYMBOLS	PARAMETERS AND CONDITIONS	UNITS	MIN	TYP	MAX
I _{CC}	Circuit Current (no signal)	mA	9	14	19.5
f _{IN}	Input Frequency at P _{IN} = -14 to -10 dBm P _{IN} = -10 to +8dBm P _{IN} = +8 to +10 dBm	GHz GHz GHz	1.0 0.5 1.0		2.7 3.0 3.0
P _{IN}	Input Power at f _{IN} = 0.5 to 1.0 GHz f _{IN} = 1.0 to 2.7 GHz f _{IN} = 2.7 to 3.0 GHz	dBm dBm dBm	-10 -14 -10		+8 +10 +10
V _{OUT}	Output Voltage Swing, Z _L = 2.2 KΩ // 8 pF	V _{P-P}	1.3	1.6	
V _{DH}	Divide Ratio Control, Input High (SW1 or SW2)	V		V _{CC}	
V _{DL}	Divide Ratio Control, Input Low (SW1 or SW2)	V		OPEN	

ABSOLUTE MAXIMUM RATINGS¹ (T_A = 25°C)

SYMBOLS	PARAMETERS	UNITS	RATINGS
V _{CC}	Supply Voltage	V	-0.5 to 6.0
V _{IN}	Switch Input Voltage	V	-0.5 to V _{CC} + 0.5
P _D	Power Dissipation ²	mW	250
T _{OP}	Operating Temperature	°C	-40 to +85
T _{STG}	Storage Temperature	°C	-55 to +150

Notes:

1. Operation in excess of any one of these parameters may result in permanent damage.
2. Mounted on 50 x 50 x 1.6 mm epoxy glass PWB, (T_A = 85°C).

RECOMMENDED OPERATING CONDITIONS

SYMBOL	PARAMETER	UNITS	MIN	TYP	MAX
V _{CC}	Supply Voltage	V	4.5	5.0	5.5
T _{OP}	Operating Temperature	°C	-40	+25	+85

INTERNAL BLOCK DIAGRAM

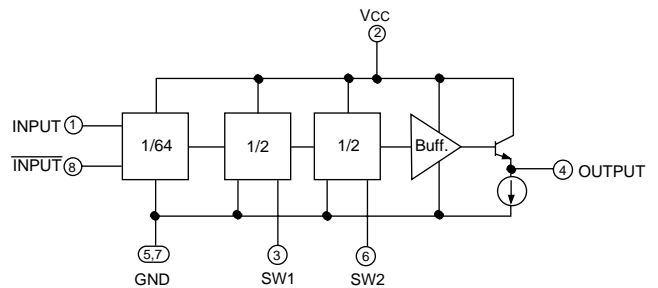

PIN DESCRIPTIONS

PIN NO.	SYMBOL	ASSIGNMENT	FUNCTIONS AND APPLICATION															
1	IN	RF Input pin	Input frequency from an external source. Must be coupled with capacitor (~1000 pF).															
2	V _{CC}	Power supply pin	Supply voltage: 5.0 ±0.5 V. This pin must be decoupled with a capacitor (~1000 pF).															
3	SW1	Divide ratio control input pin 1	<table border="1"> <thead> <tr> <th colspan="2"></th> <th colspan="2">SW2</th> </tr> <tr> <th colspan="2"></th> <th>H</th> <th>L</th> </tr> </thead> <tbody> <tr> <th rowspan="2">SW1</th> <th>H</th> <td>1/64</td> <td rowspan="2" style="text-align: center;">/</td> </tr> <tr> <th>L</th> <td>1/128</td> <td>1/256</td> </tr> </tbody> </table>			SW2				H	L	SW1	H	1/64	/	L	1/128	1/256
		SW2																
		H	L															
SW1	H	1/64	/															
	L	1/128		1/256														
6	SW2	Divide ratio control input pin 2																
4	OUT	Divided frequency output pin	Output frequency. Must be coupled with capacitor (~1000 pF).															
5 7	GND	Ground pin	This pin must be connected to the system ground with minimum inductance. Ground pattern on the board should be formed as wide as possible. (Trace length should be kept as short as possible.)															
8	\bar{IN}	Frequency-input bypass pin	This pin must be bypassed to ground through a capacitor (~1000 pF).															

TYPICAL PERFORMANCE CURVES (Unless otherwise specified $T_A = 25^\circ\text{C}$)

CIRCUIT CURRENT vs. SUPPLY VOLTAGE

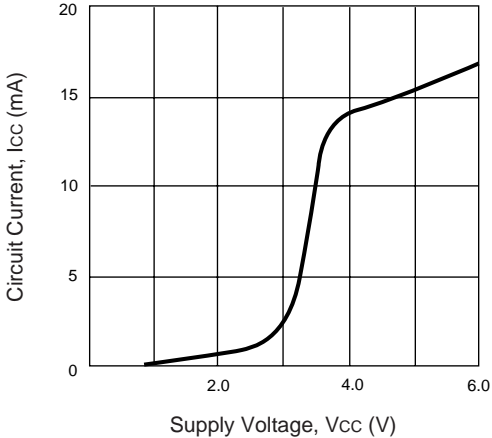

OUTPUT VOLTAGE vs. INPUT FREQUENCY AND SUPPLY VOLTAGE

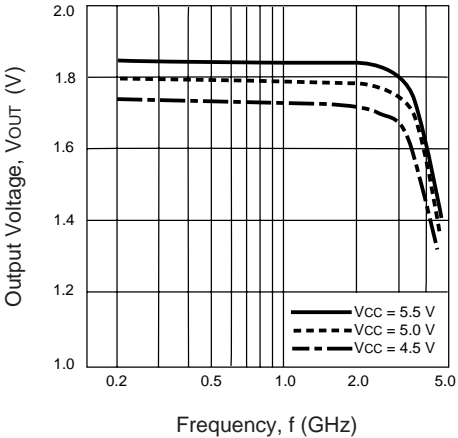

INPUT POWER vs. INPUT FREQUENCY

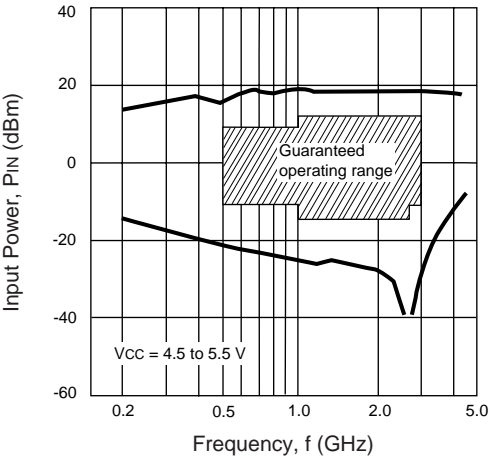

OUTPUT POWER vs. INPUT FREQUENCY AND SUPPLY VOLTAGE

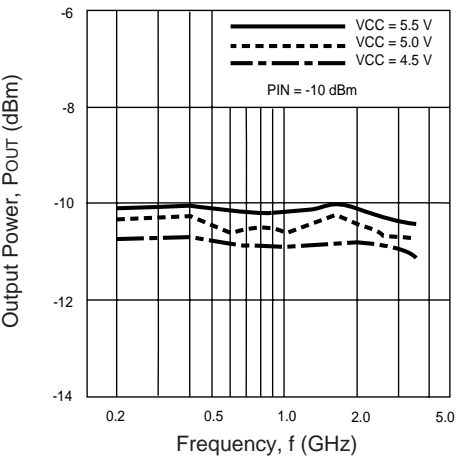

OUTPUT POWER vs. INPUT FREQUENCY AND SUPPLY VOLTAGE AT -40°C

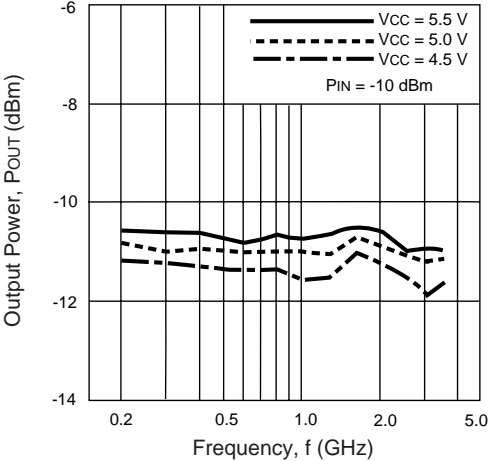

OUTPUT POWER vs. INPUT FREQUENCY AND SUPPLY VOLTAGE AT $+85^\circ\text{C}$

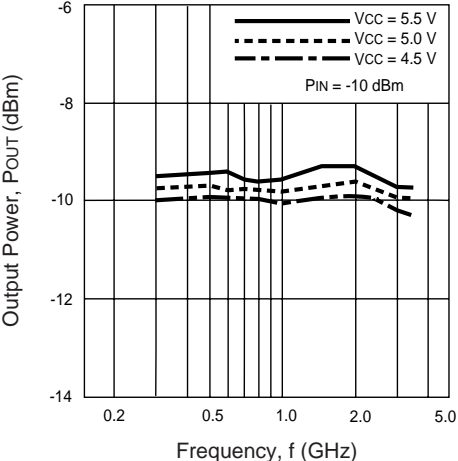

UPB1505GR

OUTLINE DIMENSIONS (Units in mm)

UPB1505GR
PACKAGE OUTLINE G08

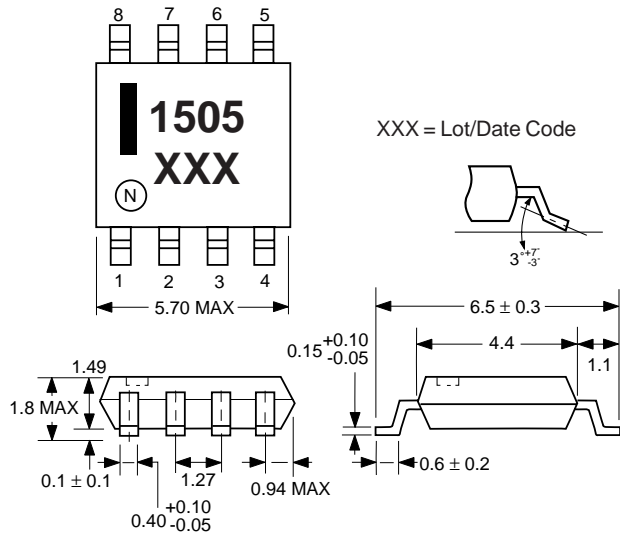

Lead Material: Alloy 42
Lead Plating: Lead-Tin Alloy

PIN CONNECTION	DESCRIPTION
1. IN	Signal Input
2. Vcc	DC Supply Voltage
3. SW 1	Divide Ratio Control #1*
4. OUT	Signal Output
5. GND	Ground
6. SW 2	Divide Ratio Control #2*
7. GND	Ground
8. IN	Signal Input Reference

* See Test Circuit

ORDERING INFORMATION

PART NUMBER	QUANTITY
UPB1505GR-E1	2500/REEL

Embossed Tape, 12 mm wide.

EXCLUSIVE NORTH AMERICAN AGENT FOR **NEC** RF, MICROWAVE & OPTOELECTRONIC SEMICONDUCTORS

CEL CALIFORNIA EASTERN LABORATORIES • Headquarters • 4590 Patrick Henry Drive • Santa Clara, CA 95054-1817 • (408) 988-3500 • Telex 34-6393 • FAX (408) 988-0279
24-Hour Fax-On-Demand: 800-390-3232 (U.S. and Canada only) • Internet: <http://WWW.CEL.COM>

DATA SUBJECT TO CHANGE WITHOUT NOTICE

PRINTED IN USA ON RECYCLED PAPER -11/97